

M.V. RAKAIA

MAIN ENGINE AND AUXILIARY MACHINERY

MAIN ENGINE

BUILDER	Harland and Wolff Limited, Belfast
TYPE	2 Cycle – Double Acting [Burmeister and Wain]
CYLINDERS	8
BORE	550 mm
STROKE	1200 + 400 mm
BHP	7500 at 115 rpm
STARTED BY	Compressed Air – maximum pressure 25 atmospheres

As can be seen from the picture on page 4, Rakaia's engine had 3 pistons to each cylinder unit. The top and bottom exhaust piston yokes were connected to 4 long rods, which were, in turn, connected to the crankshaft by a pair of eccentrics, so that the 2 exhaust pistons went up and down together.

The third, or main, piston was, in effect, 2 pistons joined together as a composite pair. The top piston of the pair operated against gases in the upper cylinder area, and the bottom piston of the pair operated against gases in the lower cylinder area. This double piston was connected to a piston rod that went through the centre of the bottom exhaust piston, and the moving joint so formed was sealed by a high pressure gland. The piston rod was then connected by a crosshead to a connecting rod that was, in turn, connected to the main crankpin on the crankshaft.

This arrangement provided a combustion chamber at each end of the stroke, one above the main piston and one below it, thus making it a double acting engine.

As Rakaia's engine had 8 cylinder units, there were 16 combustions for every revolution of the crankshaft. Each combustion was fired by 2 fuel valves connected to fuel pumps driven from the camshaft.

Although the exhaust pistons assisted in the compression process, they contributed little in the way of power output to the crankshaft because they were connected to it by eccentrics. However, the balancing effect of the 2 exhaust pistons in opposition to the double main piston was such that the

main engine could be run at an extremely low rpm. For example, dead slow was 35 rpm.

The main engine was normally run at between 101 and 102 rpm. A setting of 101.2 rpm would result in a fuel consumption of 28 tons from noon to noon. Interestingly, an increase to just 101.5 rpm would increase fuel consumption to 30 tons in the same 24 hour period. The fuel used was gas oil, which did away with the need for fuel heaters.

The scavenge air that cleared the combustion chambers after each explosion was exhausted by a scavenge blower situated at the back of the main engine and driven by a duplex chain from the crankshaft. Scavenge fires were a major problem with Rakaia's main engine. Sometimes, they could become quite severe, and the supply of fire extinguishers would soon be used up. When this happened, the Donkeyman was kept very busy up on deck refilling the fire extinguishers as fast as the engineers used them.

There also appeared to be a weakness in the design of the eccentric straps in this type of engine. Breakages were not uncommon, and, when they occurred, the results were often catastrophic.

GENERATORS

MAIN GENERATORS	4 x Diesel
OUTPUT	250 kW – 220 Volts
CYLINDERS	6
BORE	316 mm
STROKE	380 mm
BHP	335 at 420 rpm
AUXILIARY GENERATOR	1 x Diesel
OUTPUT	15 kW – 220 Volts
CYLINDERS	3
BHP	30 at 1000 rpm

Rakaia's 4 main generators were "Harlandics" also made by Harland and Wolff. These provided the engine room staff with considerable problems whilst Rakaia was at sea, although they very rarely caused any trouble in port. It is possible that these generators were originally designed for shoreside use but were installed on Rakaia due to shortages of more robust generators when she was built, towards the end of the Second World War.

On homeward bound voyages to the UK, with a full refrigerated cargo, it was vital that all 4 generators were kept running as the refrigerating machinery and all the engine room auxiliary equipment depended upon their output. If more than one generator failed, then a serious shortage of power resulted in the need to shut down such things as salt water pumps and galley supplies. This often manifested itself through a lack of deck pressure for hoses and, of course, consternation in the galley!!

On these occasions, all the engineers had to “turn too” until repairs brought the faulty generators back on line in order to prevent any lasting damage to the refrigerated cargo.

HARLAND & WOLFF DOUBLE-ACTING DIESEL

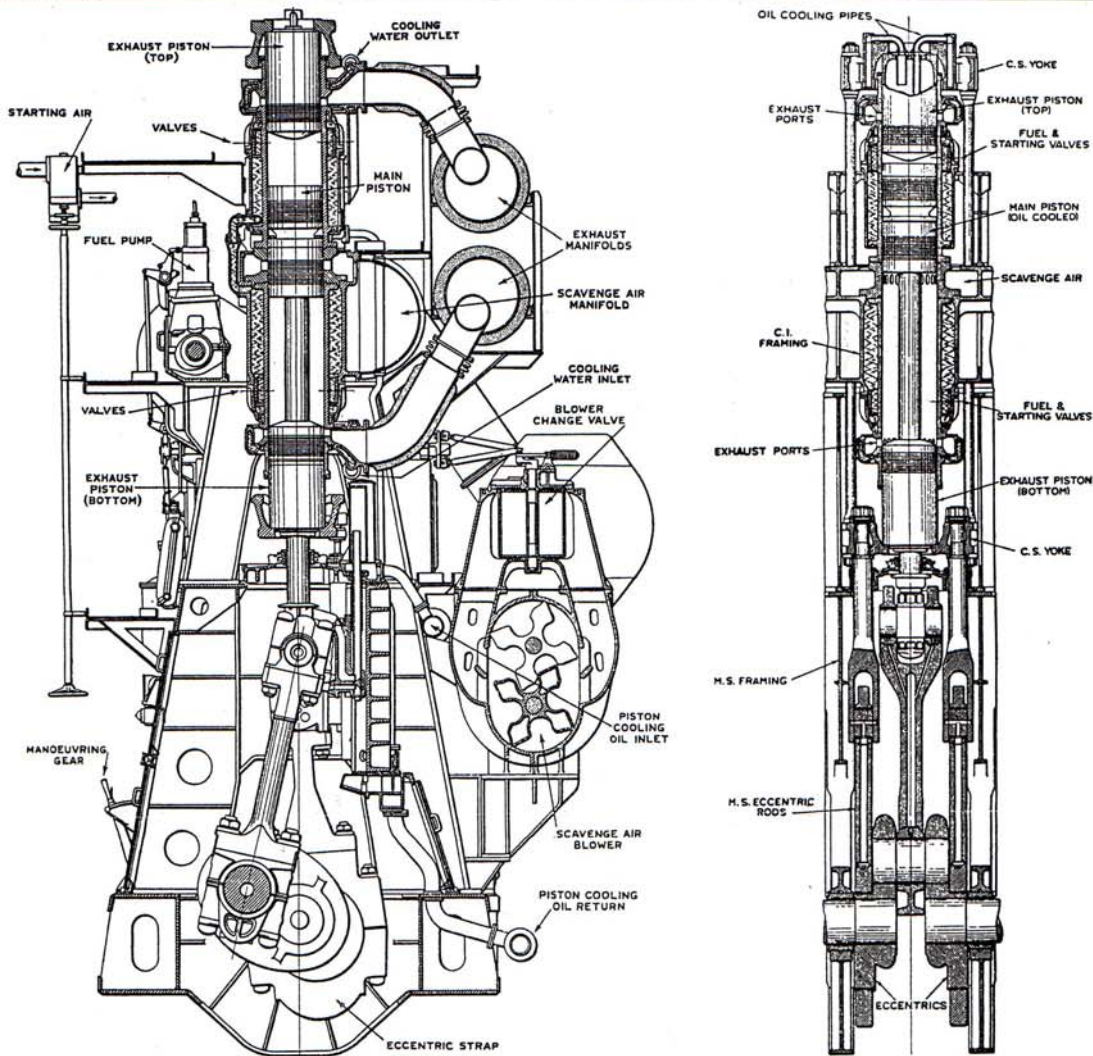

FIG. 1.—SECTIONS THROUGH HARLAND & WOLFF TWO-STROKE, DOUBLE-ACTING, OPPOSED-PISTON DIESEL ENGINE

SEQUENCE OF OPERATIONS

THE SEQUENCE OF SCAVENGING EVENTS IS SHOWN IN FIG. 3. THE ECCENTRIC ANGLE OF ADVANCE, RELATIVE TO THE CRANK, IS $5^{\circ} + 180^{\circ} = 185^{\circ}5'$. THE $5^{\circ}5'$ IS THE LEAD ANGLE.

FOR A NON-REVERSIBLE ENGINE, THE LEAD ANGLE IS ABOUT 15° ; TO ENABLE THE COMBUSTION GAS AT EXHAUST RELEASE TO FALL TO SUB-ATMOSPHERIC PRESSURE QUICKLY, THEREBY PROVIDING CONDITIONS FOR THOROUGH SCAVENGING AS SOON AS THE AIR PORT OPENS. THE MORE THOROUGH THE SCAVENGING THE GREATER THE POWER DEVELOPED. IN A MARINE ENGINE, ASTERN RUNNING HAS TO BE CONSIDERED; HENCE IT IS NECESSARY FOR THE EXHAUST GASES TO HAVE A SUFFICIENTLY FREE ESCAPE TO ENSURE THAT, AT THE POINT OF SCAVENGE PORT OPENING, THE EXHAUST PRESSURE IS SUFFICIENTLY BELOW THE SCAVENGE PRESSURE THAT A BLOW-BACK OF EXHAUST GAS INTO THE SCAVENGE MANIFOLD IS IMPOSSIBLE.

IN FIG. 2 THE EXHAUST AND SCAVENGE PERIODS ARE PLOTTED

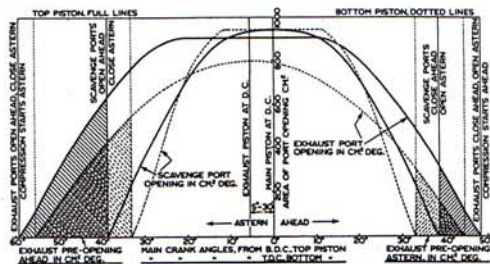

FIG. 2.—EXHAUST AND SCAVENGE PERIODS

TO A BASE OF CRANK ANGLES. THE FULL LINES ARE FOR THE TOP CYLINDER, THE DOTTED LINES FOR THE BOTTOM CYLINDER. AHEAD MOTION IS FROM LEFT TO RIGHT OF THE DIAGRAM, ASTERN MOTION FROM RIGHT TO LEFT.

WITH AHEAD ROTATION, THE TOP EXHAUST PORT BEGINS TO BE UNCOVERED BY THE EXHAUST PISTON WHEN THE CRANK IS 120° FROM TOP DEAD-CENTRE (T.D.C.) AND 60° FROM BOTTOM DEAD-CENTRE (B.D.C.). THE SCAVENGE PORT BEGINS TO BE UNCOVERED BY THE DESCENDING MAIN PISTON 20° LATER, I.E. AT 140° FROM T.D.C. OR 40° FROM B.D.C. SCAVENGE CEASES AT 40° BEYOND B.D.C. ON THE UP-STROKE; EXHAUST CLOSURE OCCURS 10° LATER, I.E. AT 50° ABOVE B.D.C.; COMPRESSION THEN BEGINS.

BOTTOM EXHAUST OPENING BEGINS AT 56° BEFORE T.D.C., FOLLOWED BY SCAVENGE OPENING AT 33° BEFORE T.D.C.; SCAVENGE CLOSURE OCCURS AT 33° BEYOND T.D.C. ON THE DOWN-STROKE, FOLLOWED BY EXHAUST CLOSURE AT 43° . COMPRESSION THEN BEGINS AND CONTINUES TO BOTTOM DEAD CENTRE.

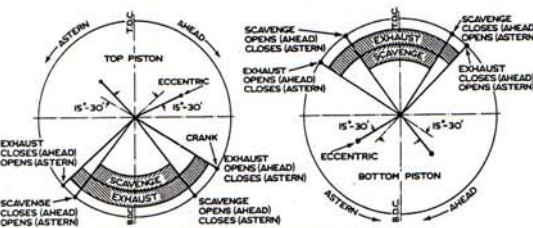

FIG. 3.—EXHAUST AND SCAVENGE PERIODS